

IMPORTANT — Please make certain that persons who are to use this equipment thoroughly read and understand this user's manual prior to operation

GASOLINE GENERATOR SET

USER'S MANUAL



CONTENTS

| | |
|-----------------------------|----|
| 1.SAFETY INFORMATION..... | 2 |
| 2.CONTROL FUNCTION..... | 3 |
| 3.PRE-OPERATION CHECK..... | 6 |
| 4.OPERATION..... | 7 |
| 5.PERIODIC MAINTENANCE..... | 10 |
| 6.TROUBLE SHOOTING..... | 13 |
| 7.STORAGE..... | 15 |
| 8.SPECIFICATIONS..... | 16 |
| 9.WIRING DIAGRAM..... | 21 |
| 10.INVERTER GENERATOR..... | 24 |

!WARNING

PLEASE READ AND UNDERSTAND THIS MANUAL COMPLETELY BEFORE OPERATING THE MATCHINE.

1 SAFETY INFORMATION

1 EXHAUST FUMES ARE POISONOUS

- Never operate the engine in a closed area or it may cause unconsciousness and death within a short time. Operate the engine in a well ventilated area.

2 FUEL IS HIGHLY FLAMMABLE AND POISONOUS

- Always turn off the engine when refueling
- Never refuel while smoking or in the vicinity of an open flame.
- Take care not to spill any fuel on the engine or muffler when refueling.
- If you swallow any fuel, inhale fuel vapor, or allow any to get in your eyes, see your doctor immediately. If any fuel spills on your skin or clothing, immediately wash with soap and water and change your clothes.
- When operating or transporting the machine, be sure it is kept upright. If it tilts, fuel may leak from the carburetor or fuel tank.

3 ENGINE AND MUFFLER MAY BE HOT

- Place the machine in a place where pedestrians or children are not likely to touch the machine.
- Avoid placing any flammable materials near the exhaust outlet during operation.
- Keep the machine at least 1 m (3 ft) from buildings or other equipment, or the engine may overheat.
- Avoid operating the engine with a dust cover.

4 ELECTRIC SHOCK PREVENTION

- Never operate the engine in rain or snow.
- Never touch the machine with wet hands or electrical shock will occur.
- Be sure to ground (earth) the generator.



NOTE:

Use ground (earth) lead of sufficient current capacity.

Ground (earth) Lead

Diameter: 0.12mm (0.005 in)/ampere

EX: 10 Ampere 1.2mm (0.055 in)



5 CONNECTION NOTES

- Avoid connecting the generator to commercial power outlet.

- Avoid connecting the generator in parallel with any other generator.

6 BATTERY

- No smoking while handling the battery.
- The battery emits flammable hydrogen gas, which can explode if exposed to electric arcing or open flame.
- Keep the area well-ventilated and keep open flames/sparks away when handling the battery

2 CONTROL FUNCTION

1 OIL WARNING SYSTEM

When the oil level falls below the lower level, the engine stops automatically.

Unless you refill with oil, the engine will not start again.

2 ENGINE SWITCH

The engine switch controls the ignition system.

- "ON"(run)

Ignition circuit is switched on.

The engine can be started.

- "OFF"(stop)

Ignition circuit is switched off.

The engine will not run.

- "START"

Starting circuit is switched on.

The starter motor starts.

EF1600L EF2600L EF4600L EF5200L EF6500L DY1500L DY2500L DY4500L DY5000L DY6500L

EF6500LE DY5000LX DY6500LX

3 AC SWITCH (N.F.B.)

The AC switch turns off automatically when the load exceeds the generator rated output.

CAUTION: _____

Reduce the load to within specified generator rated output if the AC switch (N.F.B.) turn off.

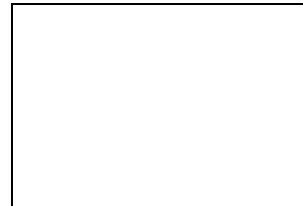
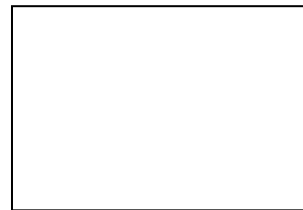
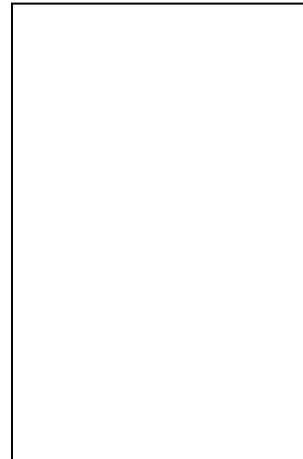

DESCRIPTION

- | | | |
|----------------------------------|-----------------------------------|-------------------------|
| (1) Fuel tank | (2) Fuel tank cap | (3) Fuel cock |
| (4) Air filter cover | (5) Spark plug | (6) Muffler |
| (7) Choke lever | (8) AC socket | (9) Engine switch |
| (10) Ground (earth) terminal | (11) Oil filler cap | (12) Oil drain plug |
| (13) Recoil starter | (14) Fuel level gauge | (15) Oil warning light |
| (16) AC switch (N.F.B.) | (17) Voltmeter | (18) DC socket (Option) |
| (19) DC circuit breaker (Option) | (20) AC output select SW (Option) | (21) Pilot light |

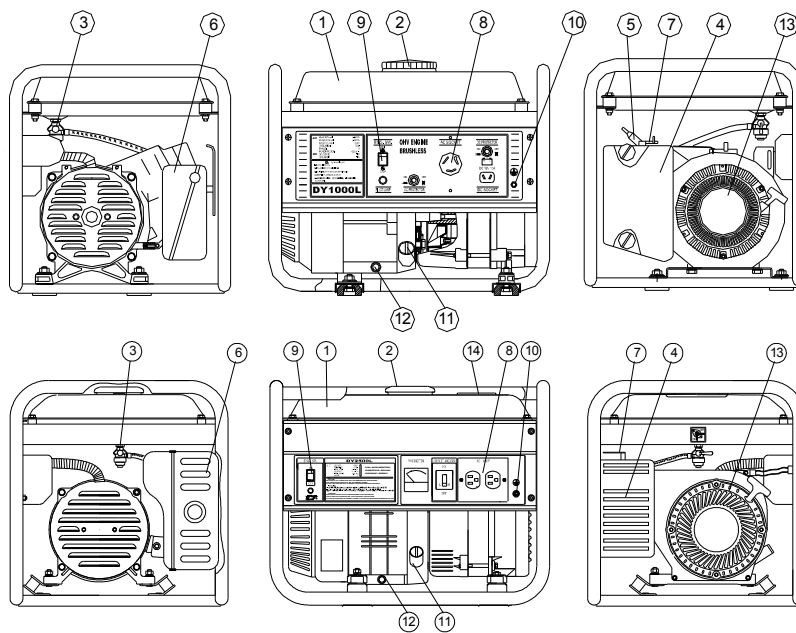

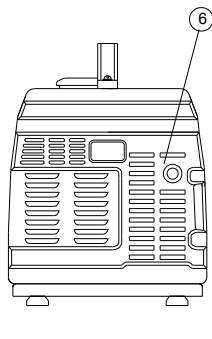

DY1000L

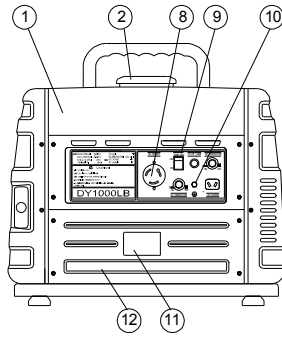

DY1000LB

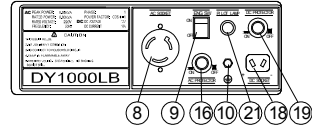
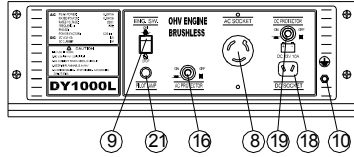
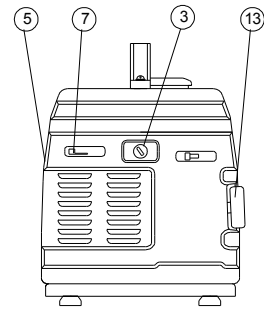

DY1500L, DY2500L

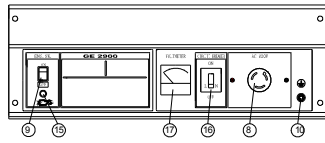

DY6500LXT

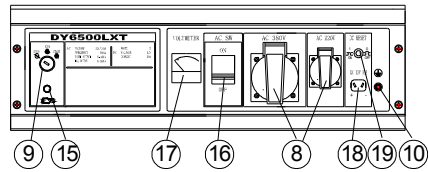

DY4500L, DY5000L

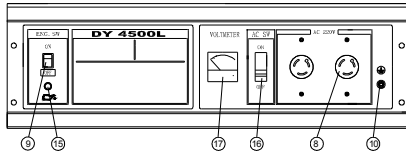

DY6500LX

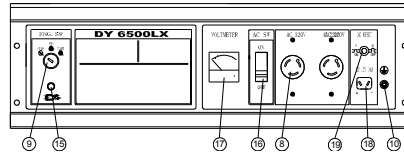

EF1600L, EF2600L

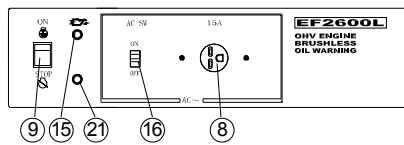

EF6600LE

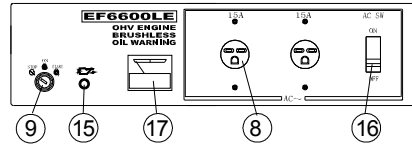

3. PRE-OPERATION CHECK

NOTE: _____

Pre-operation checks should be made each time the generator is used.



1 CHECK ENGINE FUEL

- Check fuel level at fuel level gauge.
- If fuel level is low, refill with unleaded automotive gasoline.
- Be sure to use the fuel filter screen on the fuel filter neck.
- Recommended fuel: Unleaded gasoline.
- Fuel tank capacity:

| Model | Full |
|--|------------|
| DY1000L, DY1000L1, DY1000LB, DY1500LI, DY1500LBI | 4.8 liters |
| EF1600L, EF2600L, DY1500L, DY2500L | 12 liters |
| DY4500L, DY5000L, DY6500L, DY6500LX, DY6500LXT | 22 liters |
| EF4600L, EF5200L, EF66000L, EF6600LE | 22 liters |

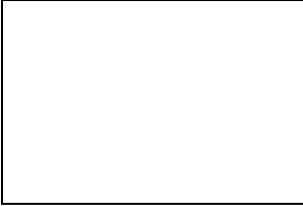

WARNING: _____

- Do not refill tank while engine is running or hot.
 - Close fuel cock before refueling with fuel.
 - Be careful not to admit dust, dirt, water or other foreign objects into fuel.
 - Wipe off spilt fuel thoroughly before starting engine.
 - Keep open flames away.
 - "F" Full, "E" Empty.
- _____

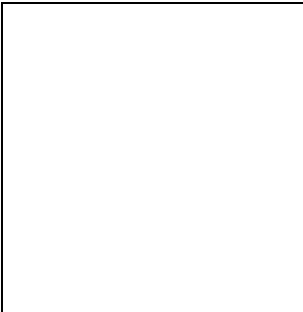

2 CHECK ENGINE OIL

Before checking or refilling oil, be sure the generator is put on a stable and level surface with engine stopped.

- Remove oil filler cap and check the engine oil level.
- If oil level is below the lower level line, refill with suitable oil to upper level line. Do not screw in the oil filler cap when checking oil level.
- Change oil if contaminated.
- Oil capacity



| Model | Full |
|--|------------|
| DY1000L, DY1000L1, DY1000LB, DY1500LI, DY1500LBI | 0.4 liters |
| EF1600L, EF2600LDY1500L, DY2500L | 0.6 liters |
| DY4500L, DY5000L, DY6500L, DY6500LX, DY6500LXT | 1.1 liters |
| EF4600L, EF5200L, EF6600L, EF6600LE | 1.1 liters |

- Recommended engine oil:
API Service "SE" or "SF", if not available, "SD".

3 GROUND (Earth)

Make sure to ground (earth) the generator.

4. OPERATION

NOTE: _____

The generator has been shipped without engine oil. Fill with oil or it will not start.

1 STARTING THE ENGINE

NOTE: _____

- Before starting the engine, do not connect the electric apparatus.
- Turn the AC switch (N.F.B.) to "OFF".

1. Turn the fuel cock lever to "ON".
2. Turn the engine switch to "ON"
3. Turn the choke lever to the " | " position. Not necessary if the engine is warm.
4. Pull the starter handle slowly until resistance is felt. This is the "Compression" point. Return the handle to its original position and pull swiftly. Do not fully pull out the rope. After starting, allow the starter handle to return to its original position while still holding the handle.
5. Warm up the engine.
6. Turn the choke lever back to the operating position.
7. Warm up the engine without a load for a few minutes.

2 USING ELECTRIC POWER

1. AC APPLICATION (SINGLE VOLTAGE TYPE)

- (a) Check the voltmeter or pilot lamp for proper voltage.
- (b) Turn off the switch(es) of the electrical appliance(s) before connecting to the generator.
- (c) Insert the plug(s) of the electrical appliance(s) into the receptacle.
- (d) Turn the AC switch to The "ON" position and turn on the electric apparatus.



CAUTION: _____

- Be sure the electric apparatus is turned off before plugging in.
- Be sure the total load is within generator rated output.
- Be sure the socket load current is within socket rated current.
- To take out power from TWIST LOCK receptacle, insert the plug into receptacle and turn clockwise to lock it.

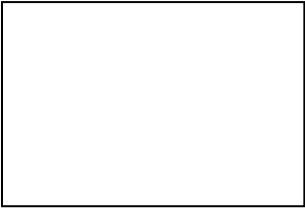

2. AC APPLICATION (DUAL VOLTAGE TYPE)

- (a) Select the voltage using the **AC OUTPUT SELECT SWITCH** in accordance with the electrical appliance.
- (b) Operate in the same way as step (a) through step (d) of single voltage type.

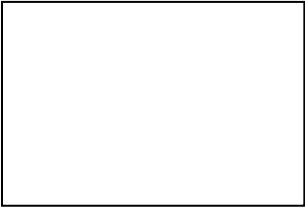

NOTE: _____

Voltmeter always indicates the lower voltage whichever the **AC OUTPUT SELECT SWITCH** is set.

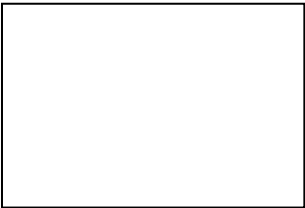

3. DC APPLICATION (option)

This usage is applicable to 12V battery charging only.

- (a) Charging instruction for battery
 - Disconnect the leads for the battery.
 - Make the battery fluid filler cap loose fully.
 - Fill distilled water to the upper limit, if the battery fluid is low level.
 - Measure the specific gravity for the battery fluid by using the hydrometer, and calculate the charging time in according with the table shown on right side.
 - The specific gravity for the fully charged battery shall be within 1.26 to 1.28. It is recommended to confirm every an hour.

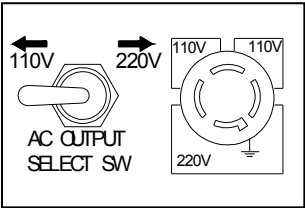

- (b) Connect between the DC output socket and the battery terminals using the charging leads. The leads shall be connected making sure of the (+) and (-) polarity.
- (c) The DC circuit protector is to be set to "ON" after confirming the connection, if the protector is in "OFF" position.

3 STOPPING THE ENGINE

- 1. Turn off the power switch of the electric apparatus or unplug the cord from receptacle of the generator. Turn the AC switch to "OFF".
- 2. Turn the engine switch to "OFF".
- 3. Turn the fuel cock lever to "OFF".

4 BATTERY

(for electric starting system)

1. REPLENISHING THE BATTERY FLUID

- Check the fluid level. The level should be between the upper and lower level marks.
- Add only distilled water if necessary.

2. BATTERY STORE

Remove the battery and charge it. Store it in a dry place and recharge it once a month. Do not store the battery in an excessively warm or cold place.

3. RECOMMENDED BATTERY

- Recommended battery: 12V/26A-h

NOTE: _____

- Clamp the red wire to the positive (+) terminal and the black wire to the negative (-) terminal of the battery. Do not reverse these positions.
- Be sure the battery is installed on the battery mount tray securely

NOTE: _____

In order to increase the longevity of your generator it is advantageous to maintain a minimum load of approximately one third the rated output.

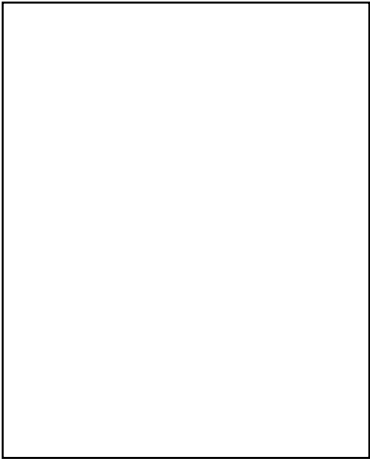

5.PERIODIC MAINTENANCE

1) MAINTENANCE CHART

Regular maintenance is most important for the best performance and safe operation.

| Item | Remarks | Pre-operation check (daily) | Initial 1 months or 20 Hr | Every 3 months or 50Hr | Every 6 months or 100Hr | Every 12 months or 300Hr |
|----------------------|---|-----------------------------|---------------------------|------------------------|-------------------------|--------------------------|
| Spark Plug | Check condition adjust gap and clean. Replace if necessary. | | | ● | | |
| Engine Oil | Check oil level | ● | | | | |
| | Replace | | ● | | ● | |
| Air Filter | Clean. Replace if necessary. | | | ● | | |
| Fuel Filter | Clean fuel cock filter. Replace if necessary | | | | ● | |
| Valve Clearance | Check and adjust when engine is cold. | | | | | ● |
| Fuel Line | Check fuel hose for crack or damage. Replace if necessary. | ● | | | | |
| Exhaust System | Check for leakage. Retighten or replace gasket if necessary | ● | | | | |
| | Check muffler screen. Clean / replace if necessary. | | | | ● | |
| Carburetor | Check choke operation | ● | | | | |
| Cooling system | Check fan damage. | | | | | ● |
| Starting system | Check recoil starter operation. | ● | | | | |
| Decarbonization | More frequently if necessary. | | | | | ● |
| Fittings / Fasteners | Check all fittings and fasteners correct if necessary. | | | | ● | |

2 ENGINE OIL REPLACEMENT

1. Place the machine on a level surface and warm up the engine for several minutes. Then stop the engine.
 2. Remove the oil filler cap
 3. Place an oil pan under the engine. Remove the oil drain plug so that the oil can be completely drained.
 4. Check the oil drain plug, gasket, oil filler cap and O-ring. If damaged replace.
 5. Reinstall the oil drain plug.
 6. Add engine oil to the upper level.
- Recommended engine oil:
API Service "SE" or "SF", if not available, "SD".

CAUTION: _____

Be sure no foreign material enters the crankcase.

3 AIR FILTER

Maintaining an air cleaner in proper condition is very important. Dirt induced through improperly installed, improperly serviced, or inadequate elements damages and wears out engines. Keep the element always clean.

1. Take out the air cleaner, clean it well in kerosene and dry it.
2. After wetting the element by clean engine oil, squeeze it tight by hand.
3. Lastly, put the element in the case and install it securely.

CAUTION: _____

The engine should never run without the element; excessive piston and/or cylinder wear may result.

4 CLEANING AND ADJUSTING SPARK PLUG

| |
|---|
| Standard electrode color: Tan Color |
| Standard Spark Plug: BPR4ES (NGK) |
| Spark Plug Gap: 0.7-0.8 mm (0.028-0.031 in) |

5 FUEL COCK

1. Stop the engine.
2. Turn the fuel cock lever to "OFF".
3. Clean with solvent.
4. Wipe off.
5. Check the gasket. Replace it if damaged.

!WARNING _____

BE sure the fuel cock cup is tightened securely.

6 FUEL TANK FILTER

- Clean with solvent.
- Wipe off.
- Fuel tank filter.

!WARNING _____

Be sure the tank cap is tightened securely.

7 MUFFLER SCREEN

!WARNING _____

- The engine and muffler will be very hot after the engine has been run.
 - Avoid touching the engine and muffler while they are still hot with any part of your body or clothing during inspection or repair.
- _____

1. Remove the muffler protector and muffler screen.
2. Clean the carbon deposits out of the muffler screen using a wire brush.
3. Check the muffler screen. Replace it if damaged.
4. Install the muffler screen and muffler protector.

- Muffler protector
- Muffler screen

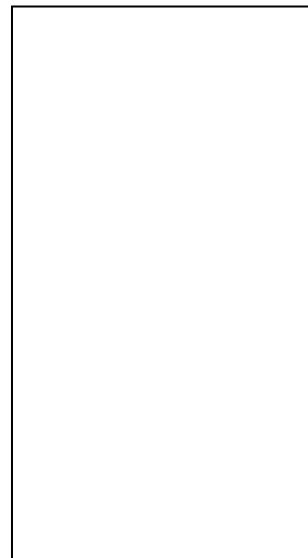
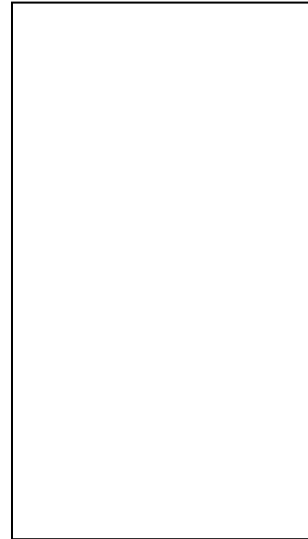

6 TROUBLE SHOOTING

ENGINE TROUBLE SHOOTING

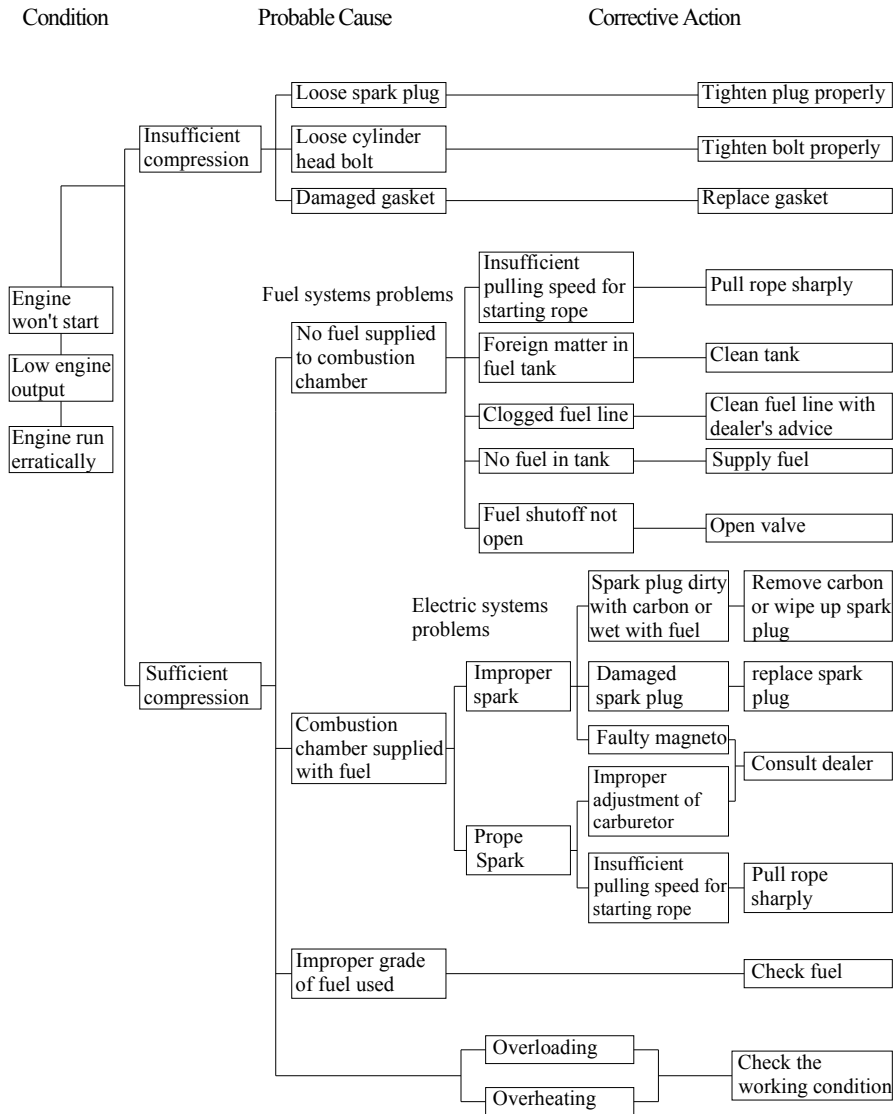

GENERATOR TROUBLE SHOOTING

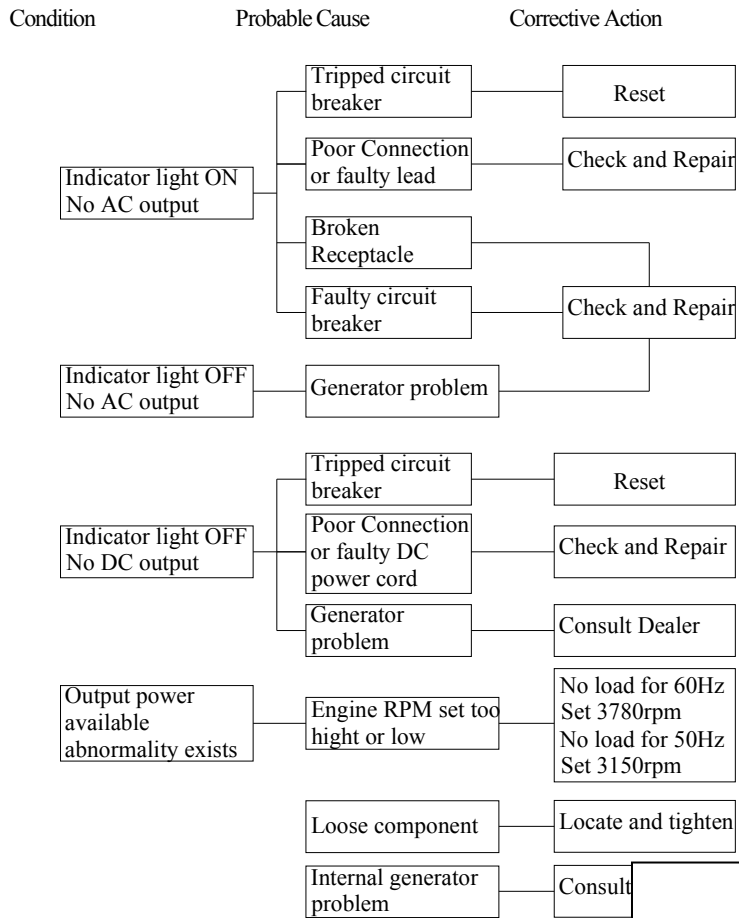

1 Engine won't start

1. Fuel systems

No fuel supplied to combustion chamber.

- No fuel in tank....Supply fuel.
- Clogged fuel line....Clean fuel line.
- Foreign matter in fuel cock....Clean fuel cock.
- clogged carburetor....Clean carburetor.

2 Engine oil system

Insufficient

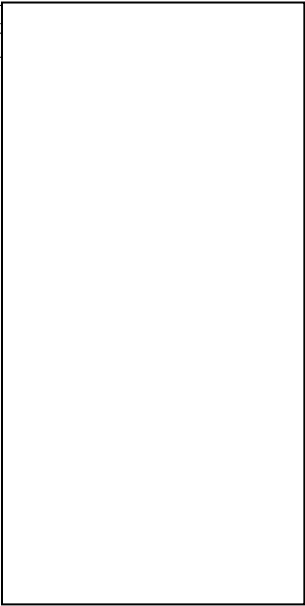

- Oil level is low...Add engine oil.

3 Electrical systems

Poor spark

- Spark plug dirty with carbon or wet...Remove carbon or wipe spark plug dry.
- Faulty ignition system...Consult dealer.

4. Compression insufficient

- Worn out piston and cylinder...Consult dealer.
- Loose cylinder head nuts...Tighten nuts properly.
- Damaged gasket...Replace gasket.

7. STORAGE

Long term storage of your machine will require some preventive procedures to guard against deterioration.

1 DRAIN THE FUEL

1. Drain the fuel tank, fuel cock, and carburetor float bowl.
2. A cup of SAE 10W30 or 20W40 motor oil.
3. Shake the tank.
4. Drain off the excess oil.

2 ENGINE

5. Pour in about one tablespoon of SAE 10W30 or 20W40 motor oil.
6. Use the recoil starter to turn the engine over several times (with ignition off).
7. pull the recoil starter until you feel compression.
8. Stop pulling.
9. Clean exterior of the generator and apply a rust inhibitor.
10. Store the generator in a dry, well-ventilated place, with the cover place over it.
11. The generator must remain in a vertical position.

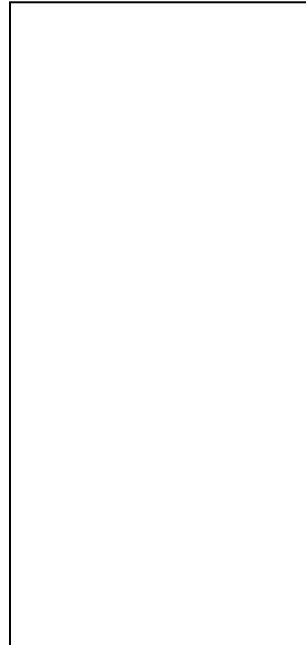

8. SPECIFICATION

| MODEL | | DY1000L | DY1000L1 | DY1000LB | |
|------------------|----------------------------|--|----------------------|-------------|-------------|
| GENERATOR | Type | Brushless, Revolving Field, Self-exciting, 2-poles, Single phase | | | |
| | AC Voltage | 50Hz | 220V,230V, 240V | | |
| | | 60Hz | 110V,120V,220V,240V, | | |
| | Max. Output | 50Hz | 0.95kVA | 0.95kVA | 0.85kVA |
| | | 60Hz | 1.0kVA | 1.0kVA | 0.90kVA |
| | Rated Output | 50Hz | 0.90kVA | 0.9kVA | 0.80kVA |
| | | 60Hz | 0.95kVA | 0.95kVA | 0.85kVA |
| | Voltage Regulator | Condenser Type | | | |
| Power Factor | 1.0 | | | | |
| DC Output | 12V/10A(Optional) | | | | |
| ENGINE | Model | MH82 | | | |
| | Type | Air-cooled, 4 cycle, OHV, Gasoline Engine | | | |
| | Bore×Stroke | mm×mm | 52×38 | | |
| | Displacement | 80cc | | | |
| | Max. Output | 2.4HP/3600rpm | | | |
| | Fuel | Regular Automobile Gasoline | | | |
| | Fuel tank Capacity | 4.5 liters | | | |
| | Rated Continuous Operation | 50Hz | 6.0 hours | 6.0 hours | 5.5 hours |
| | | 60Hz | 5.5 hours | 5.5 hours | 5.0 hours |
| | Lubricating oil | Engine Oil SD Class or Higher | | | |
| | Lubricating oil Capacity | 0.4 liter | | | |
| | Starting System | Recoil Starter | | | |
| | Ignition system | T.C.I. | | | |
| Spark Plug: Type | F6RTC BPR-4ES(NGK) | | | | |
| DIMENSION | Net dimension | L×W×H | 445×350×365 | 415×320×360 | 440×320×360 |
| | Overall dimension | L×W×H | 460×365×385 | | |
| | Net Weight | | 28 Kg | 26 Kg | 30 Kg |
| | Dry Weight | | 30 Kg | 28 Kg | 32 Kg |

- Specifications subject to change without prior notice.

| MODEL | | EF1600L | EF2600L | |
|------------------|----------------------------|--|---------------------------------------|-----------|
| GENERATOR | Type | Brushless, Revolving Field, Self-exciting, 2-poles, Single phase | | |
| | AC Voltage | 50Hz | 220V,230V,240V | |
| | | 60Hz | 110V,120V,220V,240V,110/220V,120/240V | |
| | Max. Output | 50Hz | 1.5kVA | 2.5kVA |
| | | 60Hz | 1.8kVA | 3.0kVA |
| | Rated Output | 50Hz | 1.3kVA | 2.0kVA |
| | | 60Hz | 1.5kVA | 2.5kVA |
| | Voltage Regulator | Condenser Type | | |
| Power Factor | 1.0 | | | |
| DC Output | 12V/10A(Optional) | | | |
| ENGINE | Model | MZ175L | | |
| | Type | Air-cooled, 4 cycle, OHV, Gasoline Engine | | |
| | Bore×Stroke | mm×mm | | |
| | Displacement | 68×50 | | |
| | Max. Output | 171cc | | |
| | Fuel | 5.5HP/4000rpm | | |
| | Fuel tank Capacity | Regular Automobile Gasoline | | |
| | Rated Continuous Operation | 50Hz | 12 hours | 10 hours |
| | | 60Hz | 10 hours | 8.5 hours |
| | Lubricating oil | 12 liters | | |
| | Lubricating oil Capacity | Engine Oil SD Class or Higher | | |
| | Starting System | 0.6 liter | | |
| | Ignition system | Recoil Starter | | |
| Spark Plug: Type | T.C.I. | | | |
| DIMENSION | Net dimension | F6RTC BPR-4ES(NGK) | | |
| | Overall dimension | 510×415×425 mm | | |
| | Net Weight | 40 Kg | 43 Kg | |
| | Dry Weight | 42 Kg | 45 Kg | |

- Specifications subject to change without prior notice.

| MODEL | | EF4600L | EF5200L | EF6600L | EF6600LE | |
|------------------|----------------------------|--|---------------------------------------|----------------|-------------|-----------|
| GENERATOR | Type | Brushless, Revolving Field, Self-exciting, 2-poles, Single phase | | | | |
| | AC Voltage | 50Hz | 220V,230V,240V | | | |
| | | 60Hz | 110V,120V,220V,240V,110/220V,120/240V | | | |
| | Max. Output | 50Hz | 4.0kVA | 4.5kVA | 5.5kVA | 5.5kVA |
| | | 60Hz | 4.5kVA | 5.2kVA | 6.5kVA | 6.5kVA |
| | Rated Output | 50Hz | 3.5kVA | 3.8kVA | 5.0kVA | 5.0kVA |
| | | 60Hz | 4.0kVA | 4.5kVA | 5.5kVA | 5.5kVA |
| | Voltage Regulator | Condenser Type | | | | |
| Power Factor | 1.0 | | | | | |
| DC Output | 12V/10A(Optional) | | | | | |
| ENGINE | Model | MZ300L | | MZ360L | MZ360LE | |
| | Type | Air-cooled, 4 cycle, OHV, Gasoline Engine | | | | |
| | Bore×Stroke mm×mm | 78×63 | | 85×63 | | |
| | Displacement | 301cc | | 357cc | | |
| | Max. Output | 10.0HP/4000rpm | | 12.0HP/4000rpm | | |
| | Fuel | Regular Automobile Gasoline | | | | |
| | Fuel tank Capacity | 22 liters | | | | |
| | Rated Continuous Operation | 50Hz | 10.5 hours | 9.2 hours | 8.2 hours | 8.2 hours |
| | | 60Hz | 9.0hours | 8.5hours | 7.0 hours | 7.0 hours |
| | Lubricating oil | Engine Oil SD Class or Higher | | | | |
| | Lubricating oil Capacity | 1.1 liter | | | | |
| | Starting System | Recoil Starter | | | Recoil+Self | |
| | Ignition system | T.C.I. | | | | |
| Spark Plug: Type | F6RTC BPR-4ES(NGK) | | | | | |
| DIMENSION | Net dimension L×W×H | 670×510×510 mm | | | | |
| | Overall dimension L×W×H | 690×530×550 mm | | | | |
| | Net Weight | 75 Kg | 75 Kg | 82 Kg | 88 Kg | |
| | Dry Weight | 78Kg | 78 Kg | 84 Kg | 90 Kg | |

- Specifications subject to change without prior notice.

| MODEL | | DY1500L | DY2500L | DY3000L | DY4500L | DY5000L | |
|------------------|----------------------------|--|---------------------------------------|---------------|----------------|------------|-----------|
| GENERATOR | Type | Brushless, Revolving Field, Self-exciting, 2-poles, Single phase | | | | | |
| | AC Voltage | 50Hz | 220V,230V,240V | | | | |
| | | 60Hz | 110V,120V,220V,240V,110/220V,120/240V | | | | |
| | Max. Output | 50Hz | 1.5kVA | 2.3kVA | 3.0 kVA | 4.0kVA | 4.5kVA |
| | | 60Hz | 1.8kVA | 2.8kVA | 3.3 kVA | 4.5kVA | 5.2kVA |
| | Rated Output | 50Hz | 1.3kVA | 2.0kVA | 2.5 kVA | 3.5kVA | 3.8kVA |
| | | 60Hz | 1.5kVA | 2.3kVA | 2.8 kVA | 4.0kVA | 4.5kVA |
| | Voltage Regulator | Condenser Type | | | | | |
| Power Factor | 1.0 | | | | | | |
| DC Output | 12V/10A(Optional) | | | | | | |
| ENGINE | Model | HM168F | | HM168FB | HM182F | | |
| | Type | Air-cooled, 4 cycle, OHV, Gasoline Engine | | | | | |
| | Bore×Stroke mm×mm | 68×45 | | 68×52 | 82×64 | | |
| | Displacement | 163cc | | 196cc | 337cc | | |
| | Max. Output | 5.5HP/4000rpm | | 6.5HP/4000rpm | 1.1HP/4000rpm | | |
| | Fuel | Regular Automobile Gasoline | | | | | |
| | Fuel tank Capacity | 12 liters | | | 22 liters | | |
| | Rated Continuous Operation | 50Hz | 12 hours | 11 hours | 10 hours | 10.5 hours | 9.2 hours |
| | | 60Hz | 10 hours | 9.5 hours | 8hours | 9.0 hours | 8.5 hours |
| | Lubricating oil | Engine Oil SD Class or Higher | | | | | |
| | Lubricating oil Capacity | 0.6 liter | | | 1.0 liter | | |
| | Starting System | Recoil Starter | | | | | |
| | Ignition system | T.C.I. | | | | | |
| Spark Plug: Type | F6RTC BPR-4ES(NGK) | | | | | | |
| DIMENSION | Net dimension L×W×H | 545×425×440 mm | | | 674×510×532 mm | | |
| | Overall dimension L×W×H | 560×440×460 mm | | | 700×530×550mm | | |
| | Net Weight | 40 Kg | 43 Kg | 45 Kg | 75 Kg | 75 Kg | |
| | Dry Weight | 42 Kg | 45 Kg | 48 Kg | 78 Kg | 78 Kg | |

- Specifications subject to change without prior notice.

| MODEL | | DY6500L | DY6500LX | DY6500LXB | DY6500LXT | |
|------------------|----------------------------|--|--|---------------------|----------------------|-----------|
| GENERATOR | Type | Revolving Field, Self-exciting, 2-poles, | | | | |
| | | Brushless, Single phase | | | Brush Three phase | |
| | AC Voltage | 50Hz | 220V, 230V, 240V | | | 230/400 |
| | | 60Hz | 110V, 120V, 220V, 240V, 110/220V, 120/240V | | | 240/416 |
| | Max. Output | 50Hz | 5.5kVA | 5.5kVA | 5.0kVA | 5.5kVA |
| | | 60Hz | 6.5kVA | 6.5kVA | 5.5kVA | 6.5kVA |
| | Rated Output | 50Hz | 5.0kVA | 5.0kVA | 4.5kVA | 5.0kVA |
| | | 60Hz | 5.5kVA | 5.5kVA | 5.0kVA | 5.5kVA |
| | Voltage Regulator | | Condenser Type | | | A.V.R. |
| | Power Factor | | 1.0 | | | 0.8 |
| DC Output | | 12V/10A(Optional) | | | | |
| ENGINE | Model | | HM188F | HM188FE | HM188FE | HM188FE |
| | Type | | Air-cooled, 4 cycle, OHV, Gasoline Engine | | | |
| | Bore×Stroke mm×mm | | 88×64 | | | |
| | Displacement | | 389cc | | | |
| | Max. Output | | 13.0HP/4000rpm | | | |
| | Fuel | | Regular Automobile Gasoline | | | |
| | Fuel tank Capacity | | 22 liters | 22 liters | 14 liters | 22 liters |
| | Rated Continuous Operation | 50Hz | 10.5 hours | 9.2 hours | 8.2 hours | 8.2 hours |
| | | 60Hz | 9.0 hours | 8.5 hours | 7.0 hours | 7.0 hours |
| | Lubricating oil | | Engine Oil SD Class or Higher | | | |
| | Lubricating oil Capacity | | 1.1 liter | | | |
| | Starting System | | Recoil Starter | Recoil+Self Starter | | |
| | Ignition system | | T.C.I. | | | |
| Spark Plug: Type | | F6RTC | BPR-4ES(NGK) | | | |
| DIMENSION | Net dimension L×W×H | 670×510×510mm | | 910×520×680 | 699×510×532 | |
| | Overall dimension L×W×H | 700×530×550mm | | 990×580×820 | 720×530×550 | |
| | Net Weight | 84 Kg | 87 Kg | 155Kg | 85 Kg | |

| | | | | | |
|--|------------|-------|-------|--------|-------|
| | Dry Weight | 87 Kg | 90 Kg | 165 Kg | 88 Kg |
|--|------------|-------|-------|--------|-------|

9. WIRING DIAGRAM

Remark : Specifications subject to change without prior notice.

DY1000L DY1000LB DY1000L1

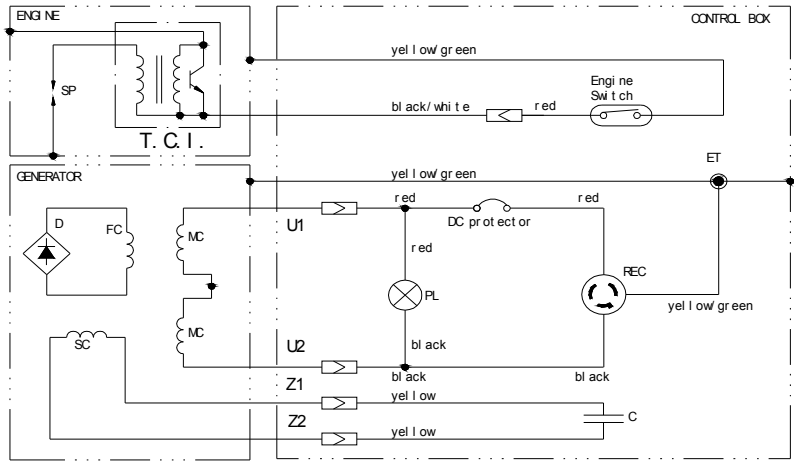

DY1500L, DY2500L, EF1600L, EF2600L (Single Voltage Type)

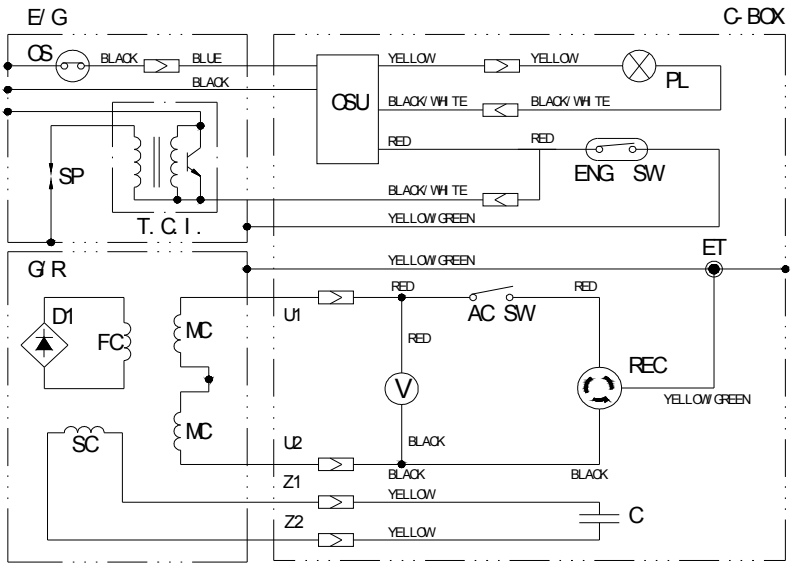

DY4500L, DY5000L, DY6500L EF4600L, EF5200L(Single Voltage Type)

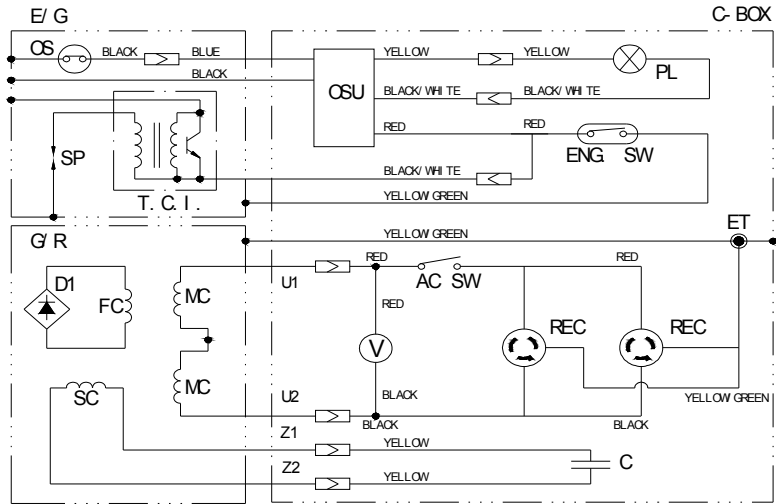

DY5000LX, DY6500LX, DY6500LXB, EF6600LE

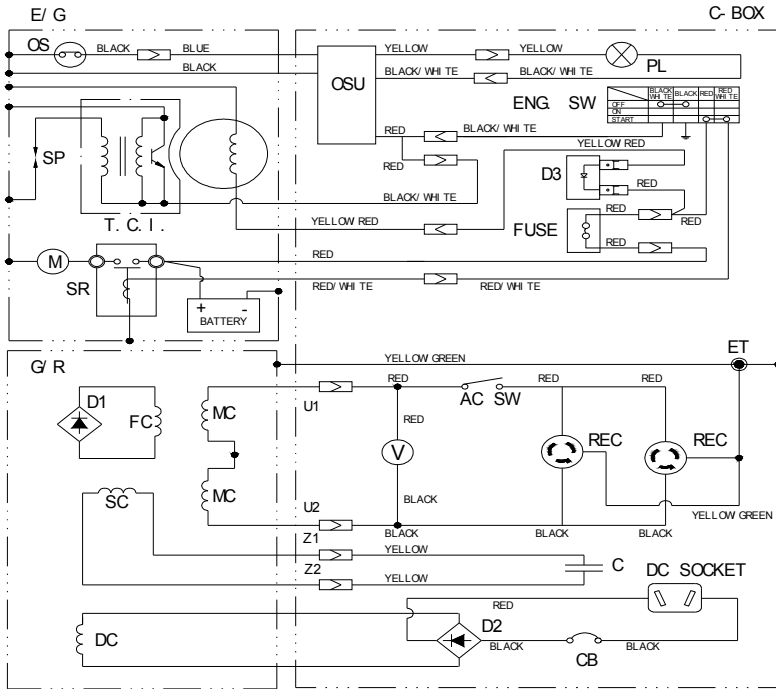

DY6500LXT

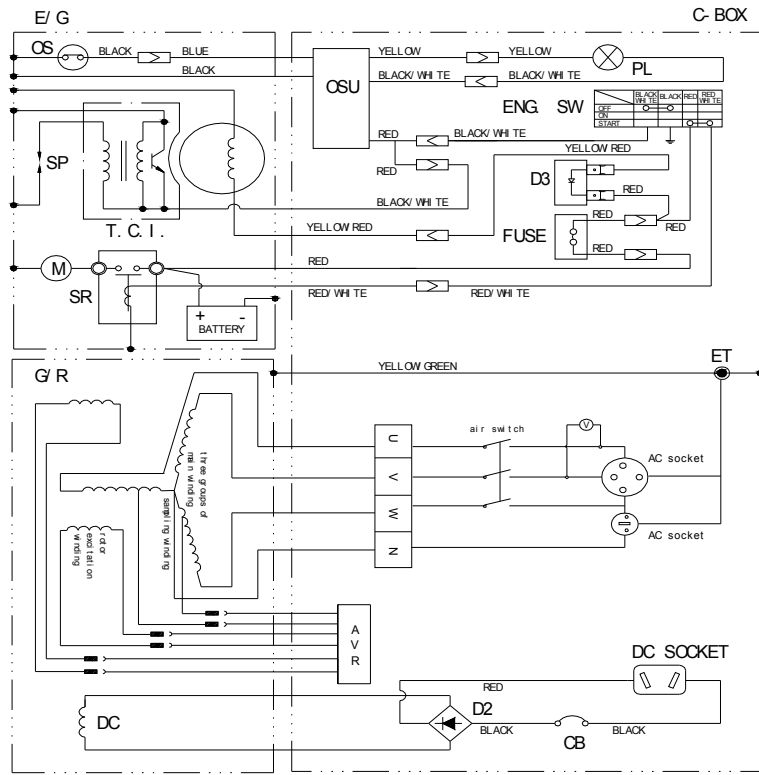

| Symbol | Parts Name | Symbol | Parts Name | Symbol | Parts Name |
|--------|--------------------|--------|-------------------|--------|------------------|
| E/G | Engine | G/R | Generator | C-BOX | Control box |
| ENG.SW | Engine stop switch | MC | AC winding | AC SW | AC switch |
| OS | Oil level gauge | SC | Auxiliary winding | V | Voltmeter |
| OSU | Oil warning unit | FC | Field winding | REC | AC socket |
| T.C.I. | T.C.I. unit | DC | Charge winding | CB | DC Circuit break |
| SP | Spark plug | D1 | Rectifier | D2 | Rectifier |
| PL | Oil pilot lamp | | | | |
| D3 | Rectifier | | | | |
| M | Starter motor | | | | |
| SR | Starter relay | | | | |

10. INVERTER GENERATOR

DESCRIPTION

- | | | |
|---------------------|------------------------------|---------------------|
| (1) Fuel tank | (2) Spark plug | (3) Air filter |
| (4) Fuel tank cap | (5) Handle | (6) Muffler |
| (7) Engine | (8) Generator | (9) Inverter |
| (10) Choke lever | (11) Fuel cock | (12) Governor |
| (13) Recoil starter | (14) Oil drain plug | (15) Oil filler cap |
| (16) AC socket | (17) Malfunction Lamp | (18) Pilot light |
| (19) Engine switch | (20) Ground (earth) terminal | |

DY1500LBI

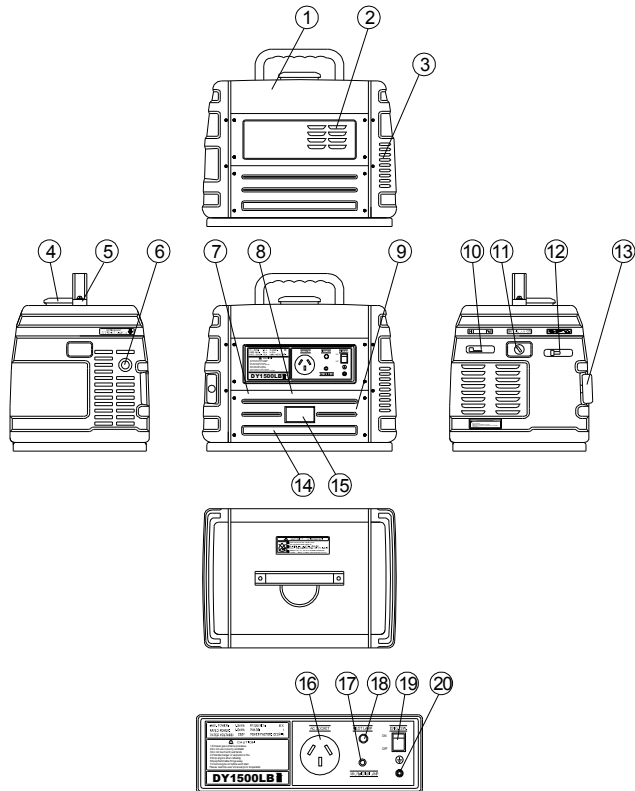

DY1500LI

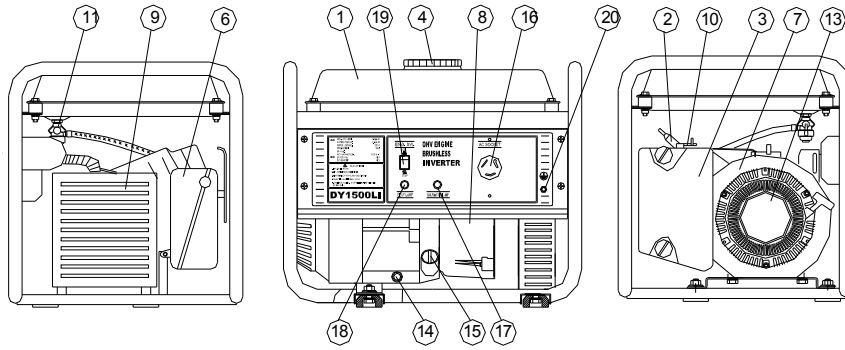

WIRING DIAGRAM

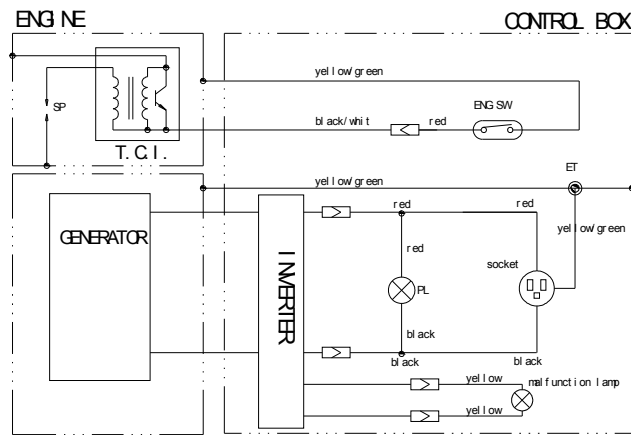

NOTE:

While the light turn on, showing no output power, please switch off the machine.

Probably problem and settle:

1. Output voltage over to tolerance, Protector works. Try to restart.
2. Short-current, Check circuit, solve problem then restart

SPECIFICATION

| MODEL | | DY1500LI | | DY1500LBI | |
|------------------|----------------------------|---|------|-----------|------|
| GENERATOR | Type | High frequency permanent magnet generator | | | |
| | Max. Output | 1.5kVA | | 1.2kVA | |
| | Rated Output | 1.2kVA | | 1.0kVA | |
| | AC Voltage | 110/220/240 | | | |
| | Frequency | 50Hz | 60Hz | 50Hz | 60Hz |
| | Phase | single | | | |
| | Power Factor | cosφ=1.0 | | | |
| | Degree of Protection | IP23 | | | |
| ENGINE | Model | MH82 | | | |
| | Type | Air-cooled, 4 cycle, OHV, Gasoline Engine | | | |
| | Bore×Stroke mm×mm | 52×38 | | | |
| | Displacement | 80cc | | | |
| | Max. Output | 2.4HP/3600rpm | | | |
| | Fuel | Regular Automobile Gasoline | | | |
| | Fuel tank Capacity | 4.8 liters | | | |
| | Rated Continuous Operation | 6.0 hours | | | |
| | Lubricating oil | Engine Oil SD Class or Higher | | | |
| | Lubricating oil Capacity | 0.4 liter | | | |
| | Starting System | Recoil Starter | | | |
| | Ignition system | T.C.I. | | | |
| | Spark Plug: Type | BPR-4ES(NGK) | | | |
| DIMENSION | Net dimension L×W×H | 445×350×365 | | | |
| | Overall dimension L×W×H | 460×365×385 | | | |
| | Net Weight | 23Kg | | 24Kg | |
| | Dry Weight | 25 Kg | | 26 Kg | |

- Specifications subject to change without prior notice.