

BODY PARTS LIST OF Venus

CONTROL ASSY.

NO.	CODE	materiel coding	DESCRIPTION	QTY.
1	40460B50T001	40460B130001	MIRROR ASSY, REAR VIEW, LH	1
2	65500B50T000	65500B130000	COWLING ASSY	1
3	65510B50T000	65510B130000	SKELETON ASSY, SUPPORT	1
4	65501B50T000	65501B130000	COWLING	1
5	40002B50T000	40002B130000	LEVER , L	1
6	40014B50T000	40014B130000	LEVER , R	1
7	40470B50T001	40470B130001	MIRROR ASSY, REAR VIEW, RH	1
8	40300B50T001	40300B130001	CABLE ASSY., THROTTLE	1
9	40180B50T000	40180B130000	MOUNTING SEAT, HANDLEBAR	1
10	40210B50T001	40210B130001	GRIP ASSY, RH(BLACK)	1
11	40250B50T000	40250B130000	CABLE ASSY., FRONT BRAKE	1
12	40270B50T000	40270B130000	CABLE ASSY., REAR BRAKE	1
13	43013B50T000	43013B130000	BRACKET, HANDLEBAR, LOWER	2
14	40500B50T000	40500B130000	SWITCH ASSY., LH	1
15	40600B50T002	40600B130002	SWITCH ASSY., RH	1
16	40001B50T001	40001B130001	GRIP, LH(BLACK)	1
17	40101B50T000	40101B130000	HANDLEBAR	1
18	43005B50T000	43005B130000	COVER, MOUNTING SEAT	1
19	43014B50T000	43014B130000	BRACKET, HANDLEBAR, UPPER	2

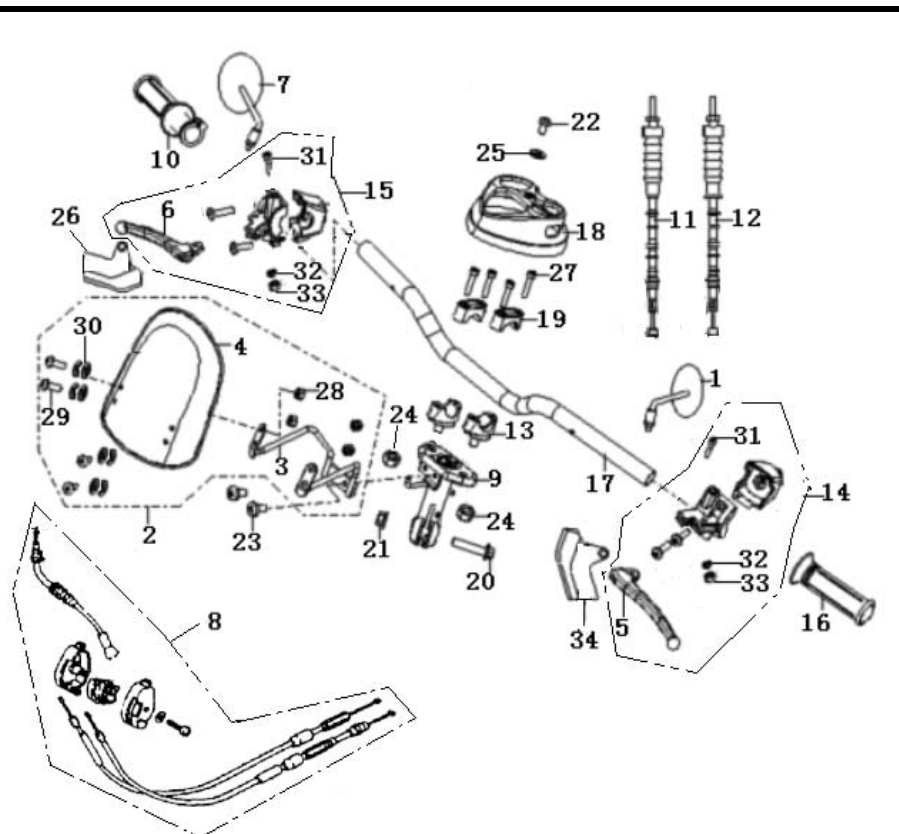

20	B01591004565	B01591004565	BOLT 10×1.25×45MM	1
----	--------------	--------------	-------------------	---

CONTROL ASSY.

NO.	CODE	materiel coding	DESCRIPTION	QTY.
21	B04171012555	B04171012555	NUT 10×1.25MM	1
22	B02000501225	B02000501225	SCREW 5×12MM	1
23	B01070601265	B01070601265	SCREW 6×12MM	2
24	B04171012555	B04171012555	NUT 10×1.25MM	2
25	B07030000505	B07030000505	WASHER 5	1
26	40008B0ET000	40008B020000	JACKET, BRAKE CABLE	1
27	B01070603064	B01070603064	BOLT 6×30MM	4
28	B04070500055	B04070500055	NUT 5MM	4
29	B02060501425	B02060501425	SCREW 5×14MM	4
30	65509B50T000	65509B130000	RUBBER WASHER	4
31	40015B50T000	40015B130000	SCREW	2
32	B07000000505	B07000000505	WASHER 5	2
33	B04000500063	B04000500063	NUT 5MM	2
34	40007B0ET000	40007B020000	JACKET, LEVER L	1

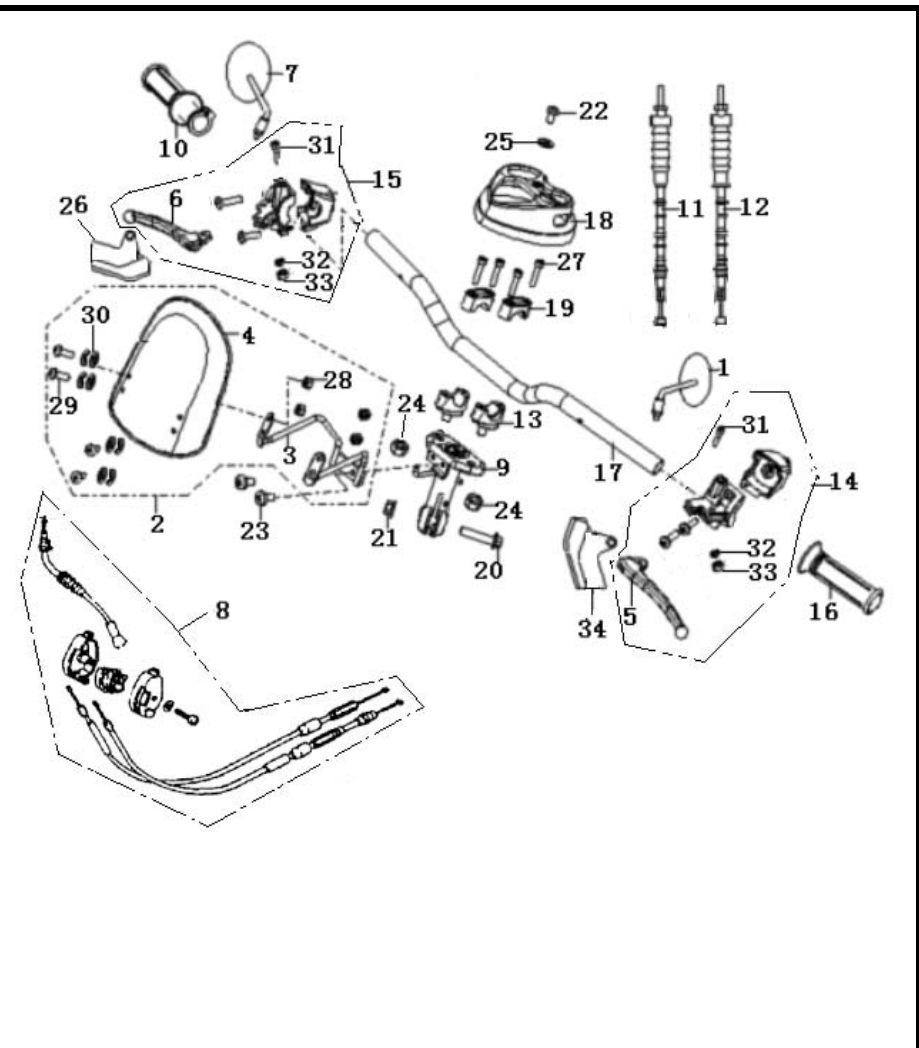

FRONT FORK ASSY.

NO.	CODE	materiel coding	DESCRIPTION	QTY.
1	43100B50T000	43100B130000	LOWER BRACKET ASSY.	1
2	43200B50T000	43200B130000	FRONT CUSHION ASSY	2
3	43910B50T000	43910B130000	SEAL ASSY	4
4	43017J0ET000	43017T020000	NUT, STEERING STEM	1
5	43001B50T000	43001B130000	RACE, UPPER, UPPER BEARING	1
6	43002B50T000	43002B130000	RACE, LOWER, UPPER BEARING	1
7	43003B50T000	43003B130000	RACE, UPPER, LOWER BEARING	1
8	43131B50T000	43131B130000	RETAINER, BEARING	1
9	43004B50T000	43004B130000	RACE, LOWER, LOWER BEARING	1
10	08011B50T000	08011B130000	BOLT	2
11	43950B50T000	43950B130000	LEVER, LH. FRONT FORK	1
12	43012B50T000	43012B130000	DECORATION PLATE	2
13	43900B50T000	43900B130000	LEVER, RH. FRONT FORK	1
14	08012B50T000	08012B130000	BOLT	2
15	43902B50T000	43902B130000	BUSH	2
16	08013B50T000	08013B130000	BOLT	2
17	43904B50T000	43904B130000	WASHER, RUBBER	2
18	B06010110000	B06010110000	BALL, STEEL	25
19	B04070800055	B04070800055	NUT 8MM	4
20	B01090601664	B01090601664	BOLT 6×16MM	2
21	43901B50T000	43901B130000	BUSH	2

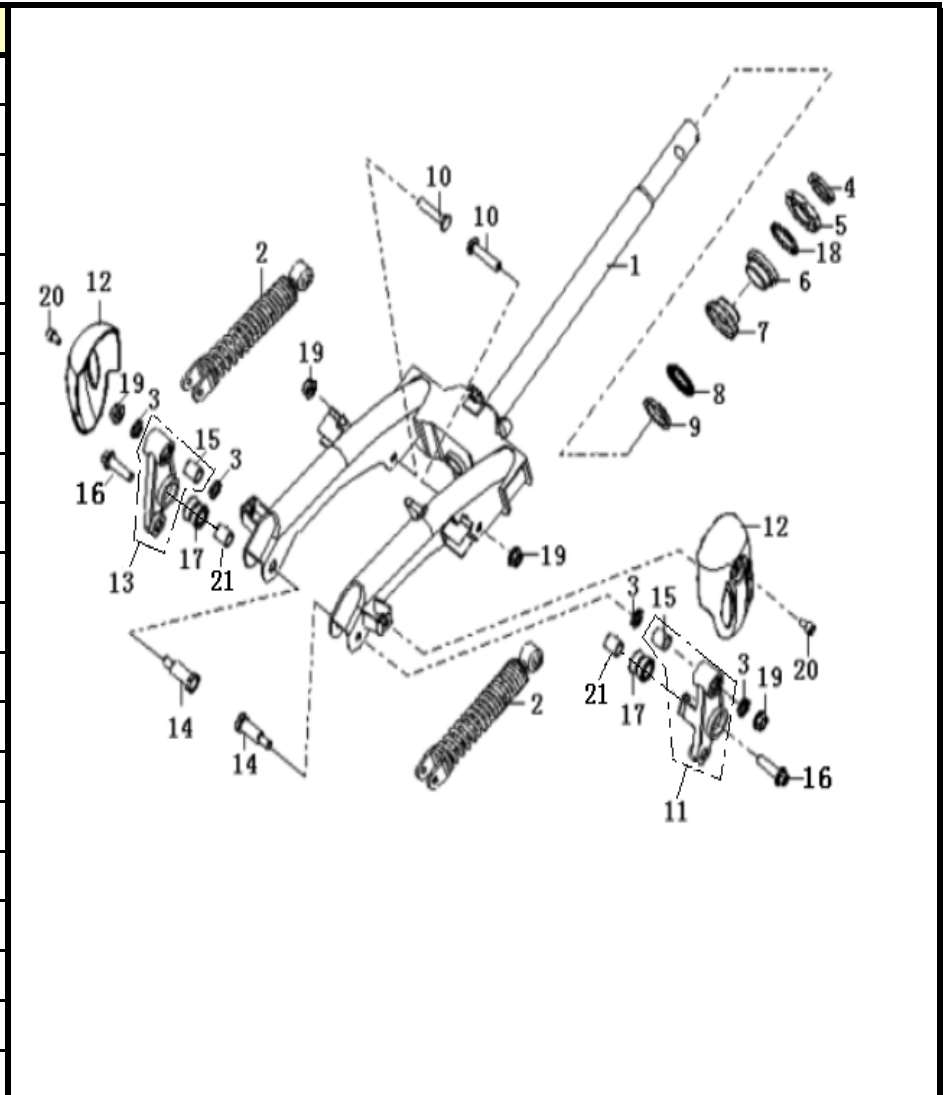

FRONT WHEEL ASSY.

NO.	CODE	materiel coding	DESCRIPTION	QTY.
1	44100B50T001	44100B130001	RIM, FRONT WHEEL	1
2	44400B0AT000	44400B040000	PANEL ASSY.	1
3	44500B0AT000	44500B040000	BRAKE SHOE	2
4	44300B0AT000	44300B040000	DUST SEAL	1
5	44004B50T000	44004B130000	AXLE, FRONT WHEEL	1
6	44201B0AT000	44201B040000	GEAR, SPEEDOMETER	1
7	44202B0AT000	44202B040000	PINION, SPEEDOMETER	1
8	44203B0AT000	44203B040000	WASHER, GEAR	1
9	44204B0AT000	44204B040000	WASHER, PINION	1
10	44205B0AT000	44205B040000	BUSH, PINION	1
11	44016B50T000	44016B130000	SPACER, RH.	1
12	44601B0AT000	44601B040000	BUSH, MID	1
13	44003B0AT000	44003B040000	CAMSHAFT, FR. BRAKE	1
14	44007B0AT000	44007B040000	LEVER, FR. BRAKE	1
15	44008B0AT000	44008B040000	SPRING, BRAKE RETURN	1
16	44001B0AT000	44001B040000	SPRING, BRAKE SHOE	2
17	44002B0AT000	44002B040000	INDICATOR, WEAR	1
18	44015B0AT000	44015B040000	SEAL, CAMSHAFT	1
19	44023B0AT000	44023B040000	PLATE, DRIVING	1
20	44602B0AT000	44602B040000	FLANGE SPACER	1

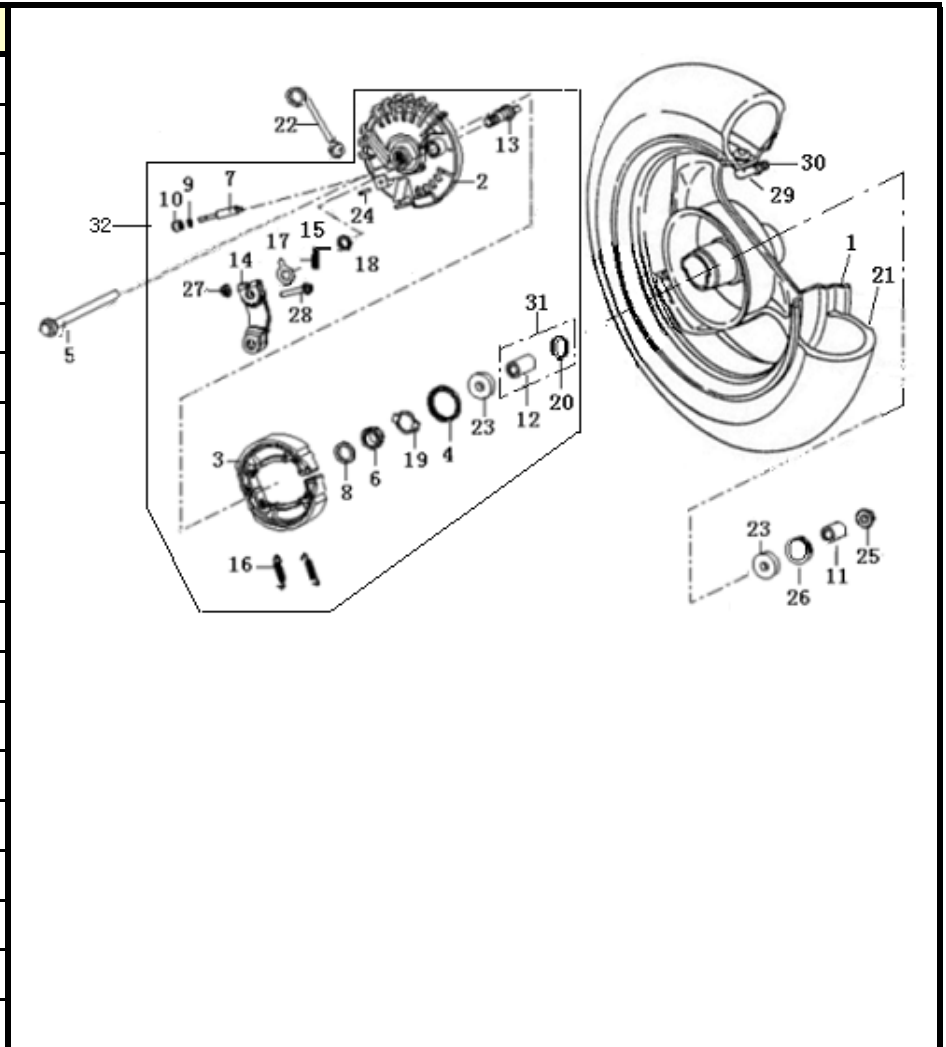

SEAT ASSY.

NO.	CODE	materiel coding	DESCRIPTION	QTY.
1	51100B50T000	51100B130000	SEAT COMP	1
2	65803J0ET000	65803T020000	NUT ASSY. 6MM	2
3	51004B50T000	51004B130000	LUGGAGE BOX	1
4	51083B50T000	51083B130000	PLATE, CONNECTING	1
5	51001B50T000	51001B130000	PIN, FIXING	1
6	51006B50T000	51006B130000	COVER, LOWER	1
7	B04070600053	B04070600053	NUT 6MM	3
8	B13060601605	B13060601605	BOLT ASSY. 6×16MM	2
9	51070B50T000	51070B130000	BRACKET COMP.	1
10	B05004801605	B05004801605	SCREW 4.8×16MM	2
11	51490B50T001	51490B130001	AIRPROOF STRIP	1

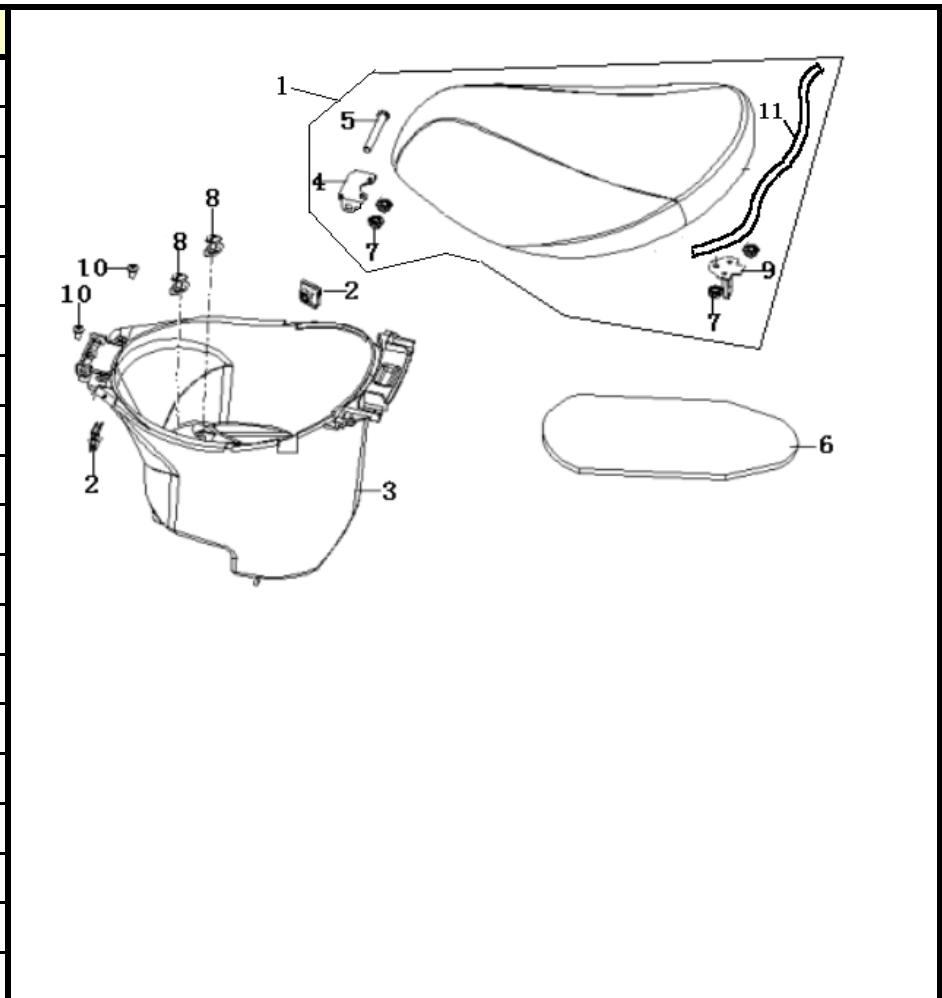

REAR WHEEL ASSY.

NO.	CODE	materiel coding	DESCRIPTION	QTY.
1	B04171415054	B04171415054	NUT 14×1.5MM	1
2	B140104F10AA	B140104F1000	TIRE (90/90-10)	1
3	B01020603265	B01020603265	BOLT 6×32MM	1
4	44100B50T001	44100B130001	RIM, FRONT WHEEL	1
5	44500B0AT000	44500B040000	BRAKE SHOE	2
6	44001B0AT000	44001B040000	SPRING, BRAKE SHOE	2
7	54003B0AT000	54003B040000	CAMSHAFT, RR.. BRAKE	1
8	B04170600055	B04170600055	NUT 6MM	1
9	54007B0AT000	54007B040000	LEVER, RR. BRAKE	1
10	B1404Z2011C0	B1404Z2011C0	CAP , VALVE	1
11	B1403Z201100	B1403Z201100	RIM , VALVE	1
12	54002B0AT000	54002B040000	INDICATOR WEAR	1
13	54008B50T000	54008B130000	TENSION SPRING	1

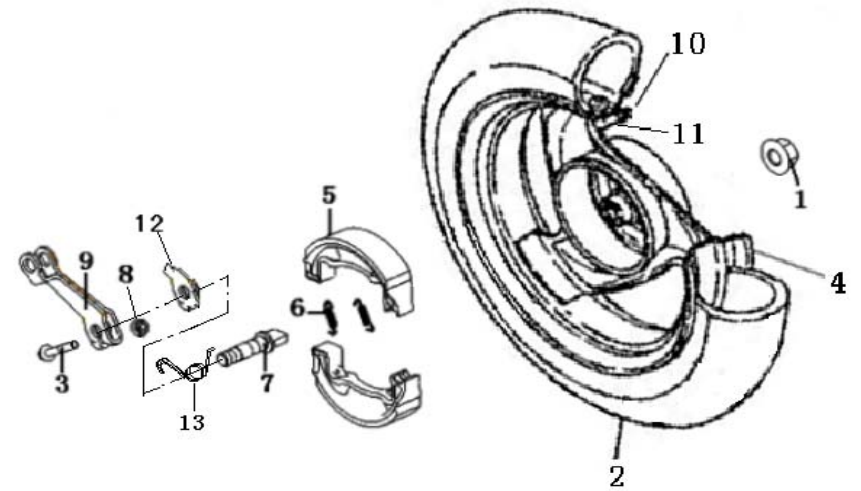

FRAME ASSY.

NO.	CODE	materiel coding	DESCRIPTION	QTY.
1	57100B50T001	57100B130001	FRAME BODY ASSY.	1
2	58300B50T000	58300B130000	BRACKET, ENGINE	1
3	57760B50T000	57760B130000	BRACKET ASSY, REAR CARRIER	1
4	58520B0DT000	58520B070000	MAIN STAND ASSY	1
5	58303B50T000	58303B130000	SHAFT, ENGINE BRACKET	1
6	58301B50T000	58301B130000	MOUNTING BOLT, BRACKET	2
7	B04171212554	B04171212554	LOCK NUT M12×1.25	1
8	B01090601664	B01090601664	BOLT 6×16MM	2
9	B04171012555	B04171012555	NUT	2
10	58030B50T000	58030B130000	SIDE STAND SEAT.	1
11	57005B50T000	57005B130000	BOLT	1
12	57003B50T000	57003B130000	RETURN SPRING	1
13	58700B50T000	58700B130000	SIDE STAND ASSY.	1
14	58502B50T000	58502B130000	SPRING , MAIN STAND	1
15	58507B50T000	58507B130000	ABSORBER PLATE,MAIN STAND	1
16	40022B0DT000	40022B070000	CLIP	1
17	57014B50T000	57014B130000	ABSORBER WASHER	1
18	96001B50T000	96001B130000	CLIP 250	3
19	B01090802065	B01090802065	BOLT 6×20MM	2
20	58501BJ0T000	58501B290000	AXLE, MAIN STAND	1

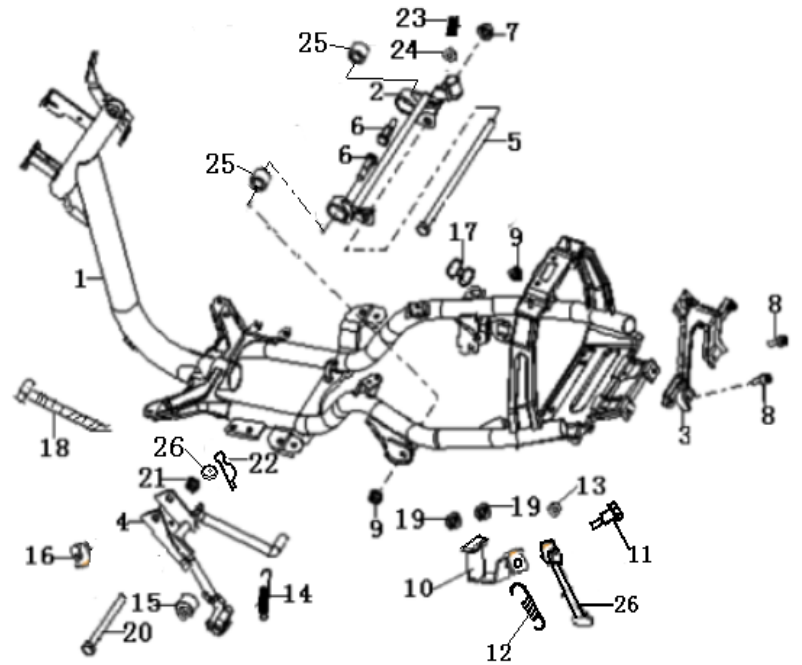
FRAME ASSY.

FRONT COVER

NO.	CODE	materiel coding	DESCRIPTION	QTY.
1	80004B13BH00	80004B13BH00	COVER, HEADLAMP BLACK	1
1	80004B13L700	80004B13L700	COVER, HEADLAMP BLUE	1
1	80004B13CA00	80004B13CA00	COVER, HEADLAMP SILVER	1
1	80004B50TY10	80004B50TY10	COVER, HEADLAMP YELLOW	1
1	80004B13RR00	80004B13RR00	COVER, HEADLAMP RED	1
2	65301B05T000	65301B130000	COVER, FRONT BLUE	1
3	65302B13BH00	65302B13BH00	COVER, LOWER (WHITE) BLACK	1
3	65302B13L700	65302B13L700	COVER, LOWER (WHITE) BLUE	1
3	65302B13CA00	65302B13CA00	COVER, LOWER (WHITE) SILVER	1
3	65302B50TY10	65302B50TY10	COVER, LOWER YELLOW	1
3	65302B13RR00	65302B13RR00	COVER, LOWER RED	1
4	65403B13BH00	65403B13BH00	CAP, FRAME NUMBER BLACK	1
4	65403B13L700	65403B13L700	CAP, FRAME NUMBER BLUE	1
4	65403B13CA00	65403B13CA00	CAP, FRAME NUMBER SILVER	1
4	65403B50TY10	65403B50TY10	CAP, FRAME NUMBER YELLOW	1
4	65403B13RR00	65403B13RR00	CAP, FRAME NUMBER RED	1
5	03310B50T000	03310B130000	HOOK, HELMET	1
6	B0206060252A	B0206060252A	SCREW 6×25MM	1
7	B0206060252A	B0206060252A	SCREW 6×25MM	1
8	B05004801205	B05004801205	SELF-TAPPING SCREW	4
9	B05075001205	B05075001205	SELF-TAPPING SCREW 5×12	2
10	B04070600055	B04070600055	NUT 6MM	1
11	B05070401205	B05070401205	SELF-TAPPING SCREW 4×12	2

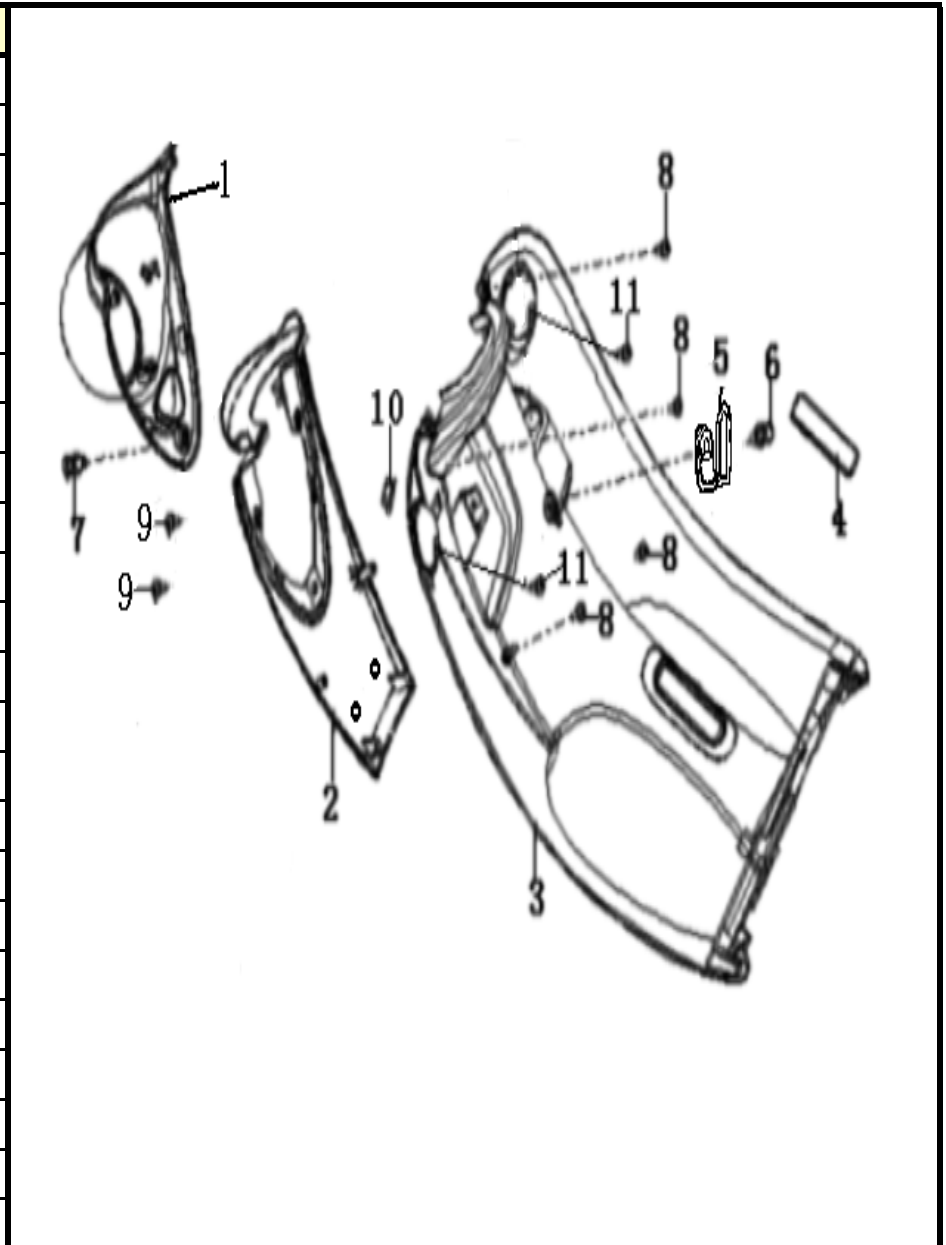

FRAME COVER ASSY.

NO.	CODE	materiel coding	DESCRIPTION	QTY.
1	08002B50T001	08002B130001	SCREW	1
2	08250B50T000	08250B130000	PLATE, NUMBER	1
3	65601B13BH01	65601B13BH01	SIDE COVER, LH BLACK	1
3	65601B13L701	65601B13L701	SIDE COVER, LH BLUE	1
3	65601B13CA01	65601B13CA01	SIDE COVER, LH SILVER	1
3	65601B50TY11	65601B50TY11	SIDE COVER, LH YELLOW	1
3	65601B13RR01	65601B13RR01	SIDE COVER, LH RED	1
4	65605B50T000	65605B130000	COVER, FRONT	1
5	65606B50T000	65606B130000	COVER, TAIL WHITE	1
6	65602B13BH01	65602B13BH01	SIDE COVER, RH BLACK	1
6	65602B13L701	65602B13L701	SIDE COVER, RH BLUE	1
6	65602B13CA01	65602B13CA01	SIDE COVER, RH SILVER	1
6	65602B50TY11	65602B50TY11	SIDE COVER, RH YELLOW	1
6	65602B13RR01	65602B13RR01	SIDE COVER, RH RED	1
7	65609B13BH00	65609B13BH00	COVER, OIL TANK BLACK	1
7	65609B13L700	65609B13L700	COVER, OIL TANK BLUE	1
7	65609B13CA00	65609B13CA00	COVER, OIL TANK SILVER	1
7	65609B50TY10	65609B50TY10	COVER, OIL TANK YELLOW	1
7	65609B13RR00	65609B13RR00	COVER, OIL TANK RED	1

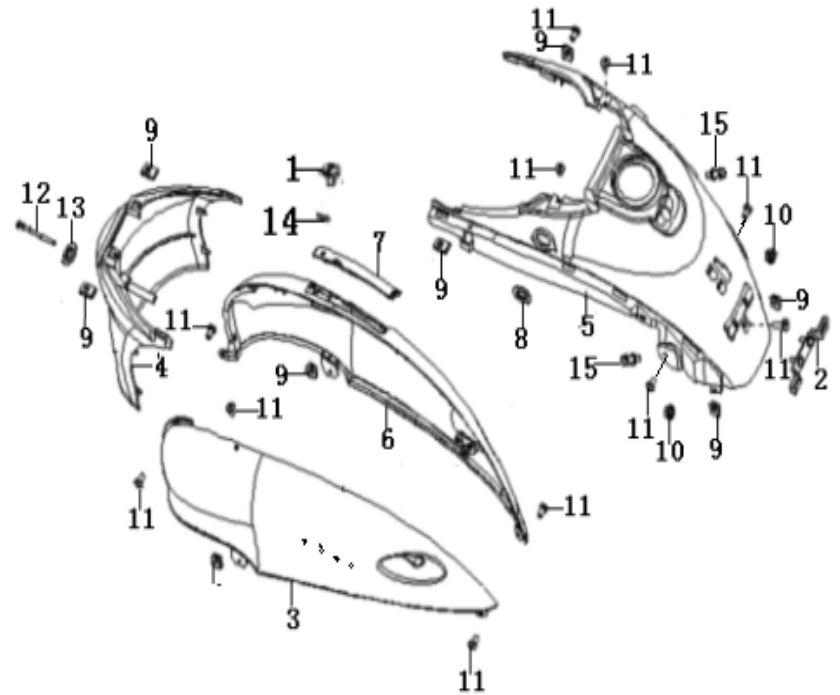

FRAME COVER ASSY.

NO.	CODE	materiel coding	DESCRIPTION	QTY.
8	05201B50T000	05201B130000	DECORATION, SEAT LOCK	1
9	65801J0ET000	65801T020000	NUT 4MM	8
10	B04070600055	B04070600055	NUT 6MM	2
11	B05004201605	B05004201605	SELF-TAPPING SCREW ST4 2x16	9
12	B02000607025	B02000607025	SCREW 6x70MM	1
13	B07030000605	B07030000605	WASHER 6MM	1
14	B090303012A4	B090303012A4	SPLIT PIN 3x12	1
15	B13060601605	B13060601605	SCREW W/WASHER 6x16MM	2
16	B05004801605	B05004801605	SELF-TAPPING SCREW ST4 8x16	2
17	B04070600055	B04070600055	NUT 6MM	2
18	86300B50T000	86300B130000	SIDE REFLEX REFLECTOR	2

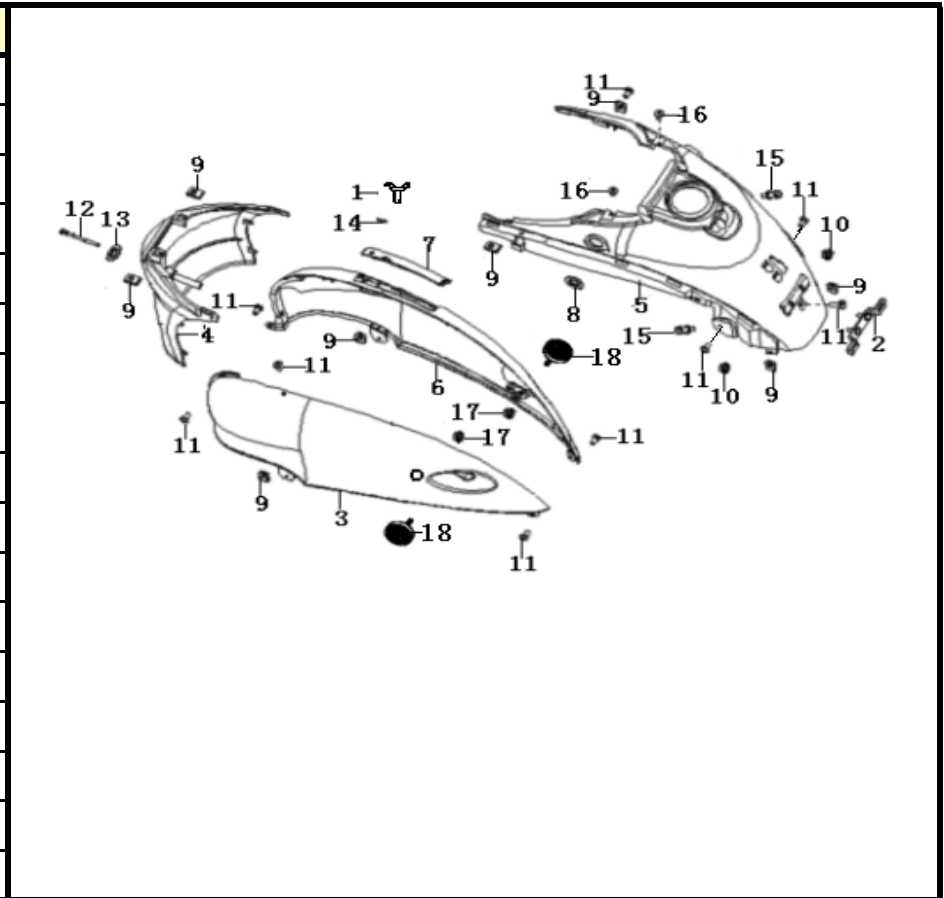

REAR FENDER ASSY.

NO.	CODE	materiel coding	DESCRIPTION	QTY.

3	88100B50T000	88100B130000	LOCK ASSY, POWER	1
4	77000B50T000	77000B130000	INDICATOR COMP.	1
5	98801B50T000	98801B130000	RECTIFIER	1
6	88800B50T000	88800B130000	LOCK ASSY, SEAT	1
7	80000B50T000	80000B130000	HEAD LAMP ASSY	1
8	82000B50T002	82000B130002	TAIL LAMP ASSY	1
9	96100B50T001	96100B130001	BATTERY	1
10	94000B50T000	94100B130000	RELAY, STARTER	1
10A	94100J000002		RELAY, STARTER	1
11	96200B50T000	96200B130000	COIL ASSY	1
12	96400B50T000	96400B130000	FLASHER	1
13	92000B130003	92000B130003	HARNESS ASSY, WIRING	1
13	92000B13000C	92000B13000C	HARNESS ASSY, WIRING	1
14	B02000601625	B02000601625	SCREW 6×16MM	1
15	81100BM0T000	81100B910000	LAMP, TURN SIGNAL, L(DOT)	1
16	81300BM0T000	81300B910000	LAMP, TURN SIGNAL, R(DOT)	1
17	72900B50T000	72900B130000	CABLE, SPEEDOMETER	1
18	B07030000605	B07030000605	WASHER 6MM	9
19	B07000000605	B07000000605	WASHER 6MM	9
20	B02000601625	B02000601625	SCREW 6×16MM	3

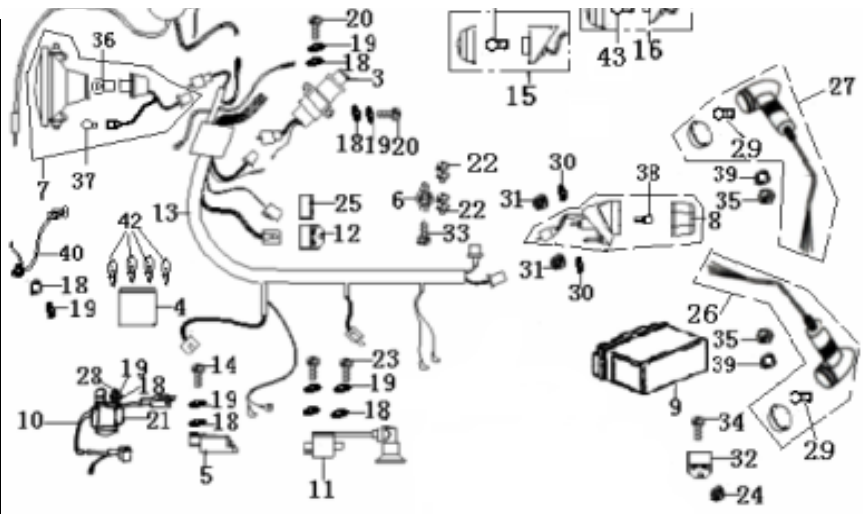

ELECTRICAL EQUIPMENT ASSY.

NO.	CODE	matériel coding	DESCRIPTION	QTY.
21	94008B50T000	94008B130000	COVER , RELAY, STARTER	1

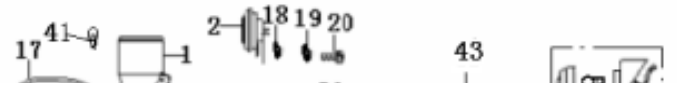

22	B13060601605	B13060601605	SCREW W/WASHER 6×16MM	2
23	B02000602025	B02000602025	SCREW 6×20MM	2
24	B04070600055	B04070600055	NUT 6MM	1
25	96401B50T000	96401B130000	COVER, FLASHER	1
26	81500B50T000	81500B130000	FLASHER LIGHT, L	1
27	81700B50T000	81700B130000	FLASHER LIGHT, R	1
28	B04000600045	B04000600045	NUT 6MM	1
29	B24021021202	B24021021202	BULB, 12V/10W (YELLOW)	2
30	B07020000505	B07020000505	WASHER 5MM	2
31	B04000500045	B04000500045	NUT 5MM	2
32	97701B50T000	97701B130000	C.D.I.	1
33	B02000601625	B02000601625	SCREW 6×12MM	1
34	B01090602065	B01090602065	BOLT 6×20MM	1
35	B04000600045	B04000600045	NUT 6MM	2
36	80002B50T000	80002B130000	BULB , 12V/35/35W	1
37	80023B50T000	80023B130000	BULB , 12V/3W	1
38	B24020722301	B24020722301	BULB , 12V/21W/5W	1
39	B07020000605	B07020000605	WASHER 6MM	2
40	96900B50T000	96900B130000	WIRE, EARTH	1

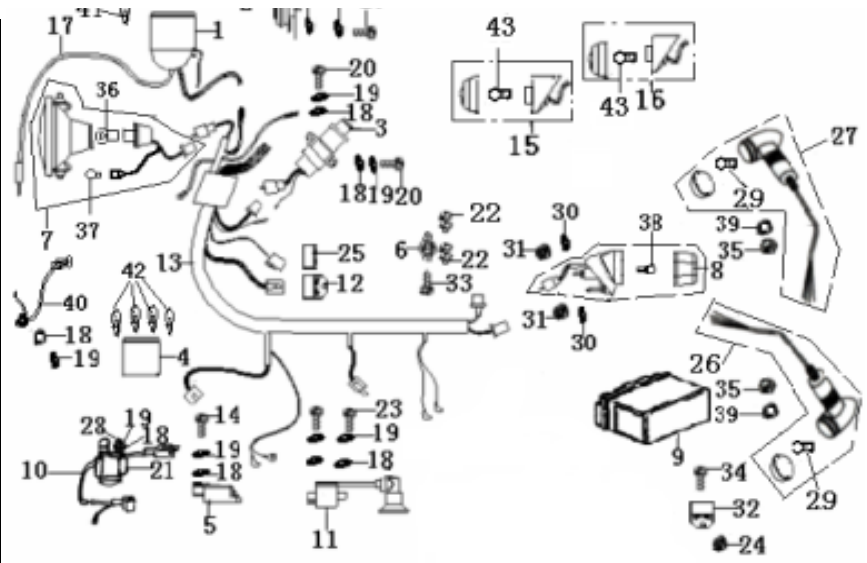

ELECTRIC I

NO.	CODE	materiel coding	DESCRIPTION	QTY.
41	70001B50T000	70001B130000	BULB , 12V1.7W	1
42	70002B50T000	70002B130000	BULB , 12V2W	4



TOOL KIT ASSY.

NO.	CODE	materiel coding	DESCRIPTION	QTY.
1	02110B50T000	02110B130000	BAG, TOOL KIT	1
2	02104B50T000	02104B130000	HANDLE, SCREW DRIVER	1
3	02101B50T000	02101B130000	SOCKET, SPARK PLUG	1
4	02103B50T000	02103B130000	DRIVER, DOUBLE-ENDED	1
5	02108G0BP000	02108G010000	WRENCH	1
6	B20011001203	B20011001203	WRENCH, DOUBLE-ENDED	1

